

# Upanels

## Upanel1.2S Intelligent Front Access 16:9 LED Display Unit



Product features:

1. Intelligent front maintenance – software maintenance and smart bracelet induction maintenance
2. HDR highly dynamic display\*
3. Revolutionary separate structure of cabinet and module
4. Seamless splicing between cabinets and between cabinet and module
5. Highly precise intelligent module

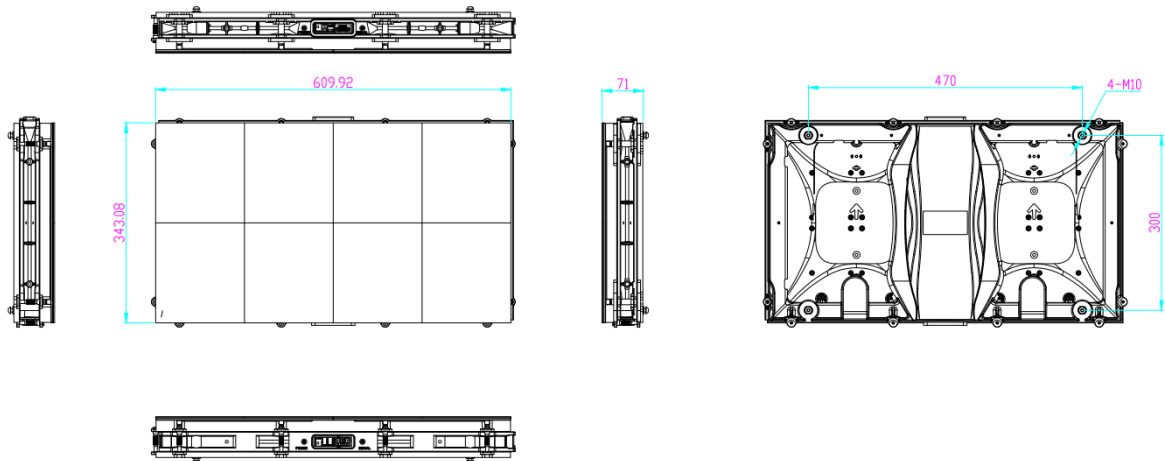

## Main Technical Specifications:

Parameter	Value
Pixel Pitch	1.27mm
LED Type	3-in-1 SMD
Brightness	600cd/m <sup>2</sup>
Pixel Density	62,000pixels /m <sup>2</sup>
Pixels Per Panel	480x270 pixels
Module Size	304.96mmx343.08mm
Panel Size	609.92mmx343.08mmx71mm
Weight	6.8kg/panel
Maintenance	Front
Ingress Protection	Rear IP20
Suggested Curve	0°~3° Concave
Panel t Diagonal	27.5"
Aspect Ratio	16:9
Panel Area	0.209 m <sup>2</sup>
Planeness	≤0.15mm
Recommended Viewing Distance	≥1.2m
Environment	Indoor
Material	Die-cast Magnesium & Aluminum
Calibration	Support brightness and chroma
Color Temperature	2,000K-9,500K Adjustable
Horizontal Viewing Angle	160°
Vertical Viewing Angle	160°
Contrast Ratio	5000:1
Input Power <Max>	140W/panel± 10% tolerance
Input Power <Typical>	46W/panel± 10% tolerance
Input Voltage	100~240 VAC
Processing Depth	20bit
Refresh Rate	3840 Hz
Video Frame Rate	60Hz~120Hz
Input Power Frequency	50~60 Hz
LED Life Time	100,000 Hours
Operating Temperature/Humidity	-10℃~+45℃/10~80%RH
Storage Temperature/Humidity	-20℃~+55℃/10~85%RH
Standard Mounting Configuration	Wall-mounting, Fixed
Optional Mounting Configuration	Concave
Certification	UL/FCC/IC/CE/CB/CCC

### Note:

1. Product pictures are for illustration only, the actual product effects (including but not limited to appearance, color, size) may be slightly different, please refer to the actual product.
2. The specification parameters are reference values. Part of the data comes from Unilumin's internal laboratory and is obtained under a specific test environment. In actual use, it may be slightly different due to product batch differences, configuration differences, software versions, use conditions and environmental factors. Actual usage shall prevail.
3. Brightness and Power consumption are based on theoretical data after calibration.